

## Overview

The Dotworkz D2-HB-PD is an engineered outdoor housing system that is designed to allow most indoor PTZ & mini-dome camera models to allow for quick installation using superior sealed D2 Pressurized housing solution into a complete rugged outdoor system solution.

Virtually Indestructible housing solution for the a wide array of harsh environments. IP68 NEMA 4X ingress protection of housing, provides the highest levels of protection from water, dust, marine, and vandal abuse, that can be pressurized with Nitrogen or Instrument Air.

## Key Features

- Designed to provide Housing capable of up to 5 psi Pressurization by installer using nitrogen, or other inert or shield gas for added sealed protection for a variety of deployment protection needs
- Two integrated Schrader Valves for pressurizing and purging
- External RJ-45 Quick Connect Integrated for quick installation
- External Power Quick Connection kit Integrated for easy powering and quick installation
- Integrated Thermostatically controlled Heater
- Integrated 10 CFM Blower fan
- Vandal Tough Housing protection
- Easy Access / Easy Install of customer supplied camera

## Applications

Easily Integrate camera and housing into a wide range of outdoor applications, to allow camera and housing to be pressurized. Extra heavy duty Dotworkz Housing is wall mount ready. The EZ Lock Pole & Speedy mount (# BR-MPM1) is available & sold separately for additional mounting options, as well as corner, parapet, and a whole line of other specialty mount brackets are available, sold separately, for virtually any mounting needs.

Good for commercial, Industrial, remote, coastal, and wide range of environmentally challenging installation.

## Shipping Specifications

Product Number	Product Weight	Product Dimensions
D2-HB-PD	7.4 lbs	15.0"l x 11.7"w x 13.4"h
	Shipping Weight	Shipping Dimensions
	11 lbs	17"l x 13"w x 16"h

## Product Attributes

- External Quick Ethernet & Power Connector set for quick installation
- Vandal Tough casing designed to protect valuable electronics from environment, vandalism, and theft
- Housing meets IP68 rating: Airtight and sealed against outside air, dust, insects, water / salt fog and other conditions
- Internal mounting space for most indoor PTZ or dome cameras; nearly all makes and models

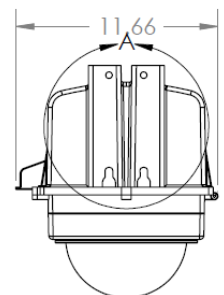
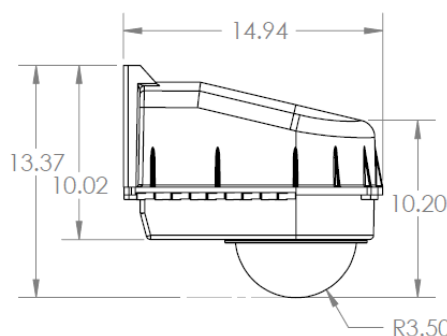
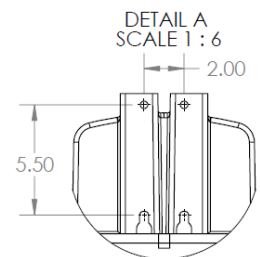
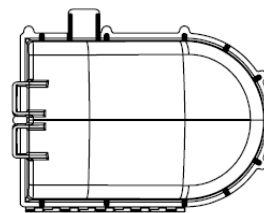

\*Product specifications are subject to change without notice